

## Prezentare rezultate

**Etapa 1** Studiu privind oportunitatea elaborării unei strategii comune, noi și originale de prevenire a poluării Dunării cu produse petroliere, evaluarea potențialului de dezvoltare a cercetărilor în domeniu.

- Elaborarea unui studiu care să cuprindă:
  - Identificarea surselor de poluare cu produse petroliere.
  - Legislația în acest domeniu din România și Bulgaria.
  - Calitatea apei Dunării.
  - Impactul poluării.
  - Strategiile de combatere a poluării.
  - Managementul riscului.
  - Metode de intervenție utilizate.

**Etapa 2** Studiu privind desemnarea parametrilor tehnologici și constructivi ce trebuie urmărit. Elaborarea temei de proiect preliminar

- Elaborarea unui studiu care să cuprindă:
  - Metode noi de cercetare a deșeurilor ecologice
  - Separarea centrifugală a deșeurilor de ulei.
  - Aspecte teoretice ale fenomenului de separare centrifugale.
  - Dezvoltarea temei proiectului preliminar

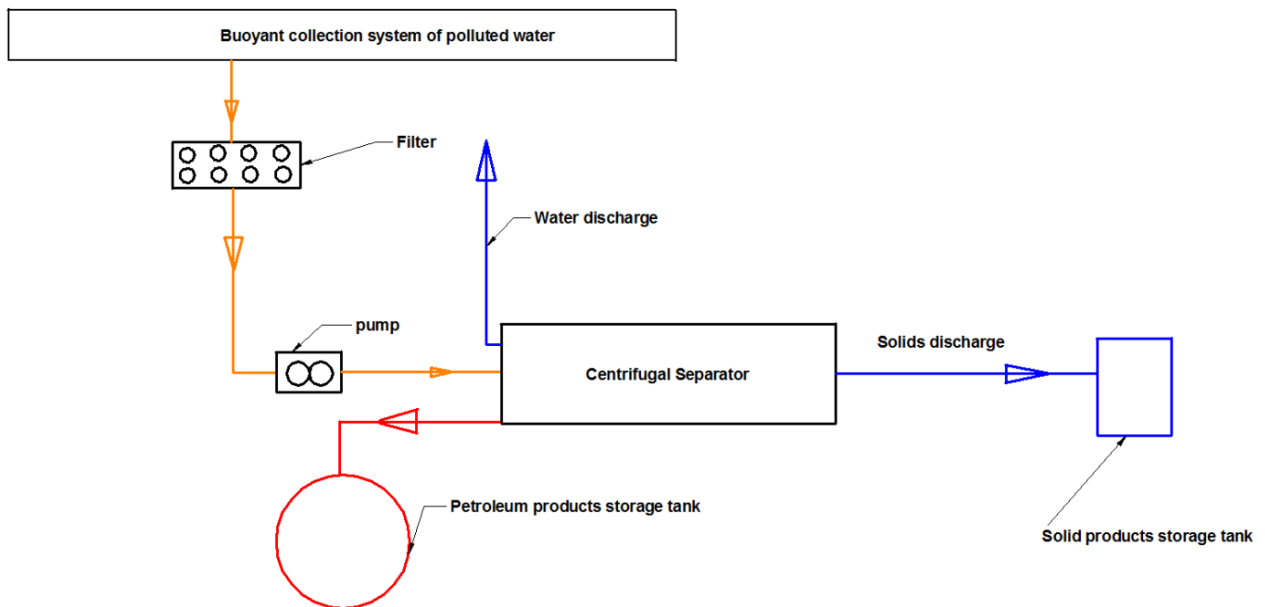

Schema generală pentru sistemul de separare a deșeurilor petroliere

**Etapa 3** Studiu privind variantele constructive posibile, implicații tehnologice. Definitivarea temei de proiect

- Elaborarea unui studiu care să cuprindă:
  - Variantele constructive posibile.
  - Implicații tehnologice.
  - Definitivarea temei de proiect

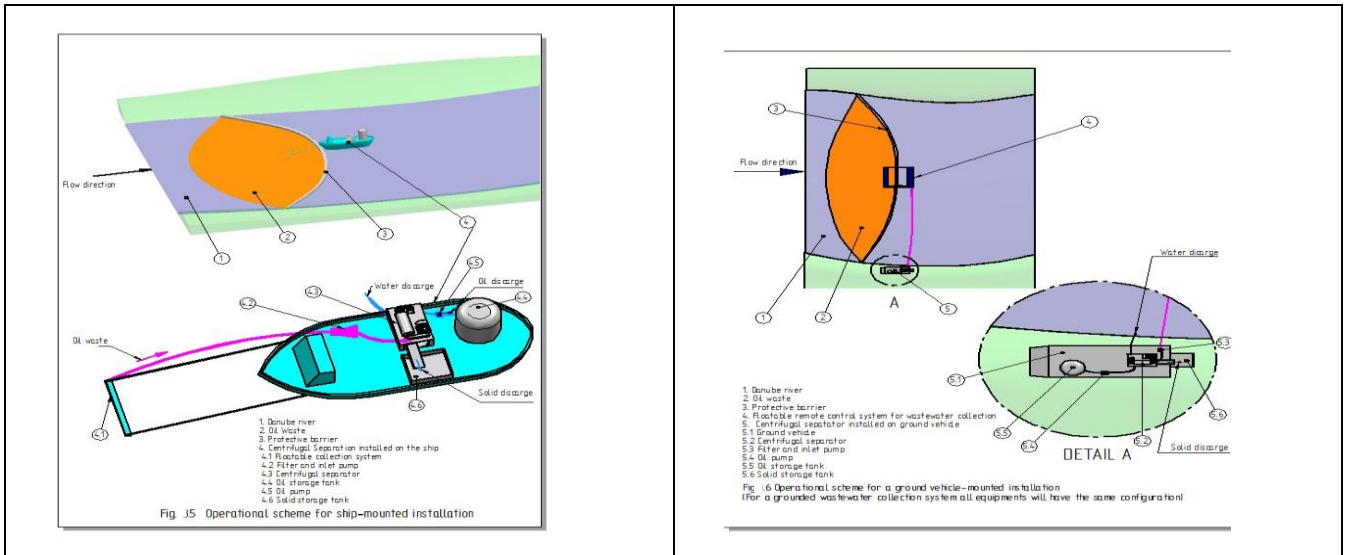

Variantele constructive posibile.

**Etapa 4 Proiect tehnic al unei solutii noi de epurare a apelor infestate cu produse petroliere**

- Proiect echipament special de procesare prin centrifugare a apei poluate cu petrol, intr-o singura treapta si separarea in produse ecologice, apa solide si petrol

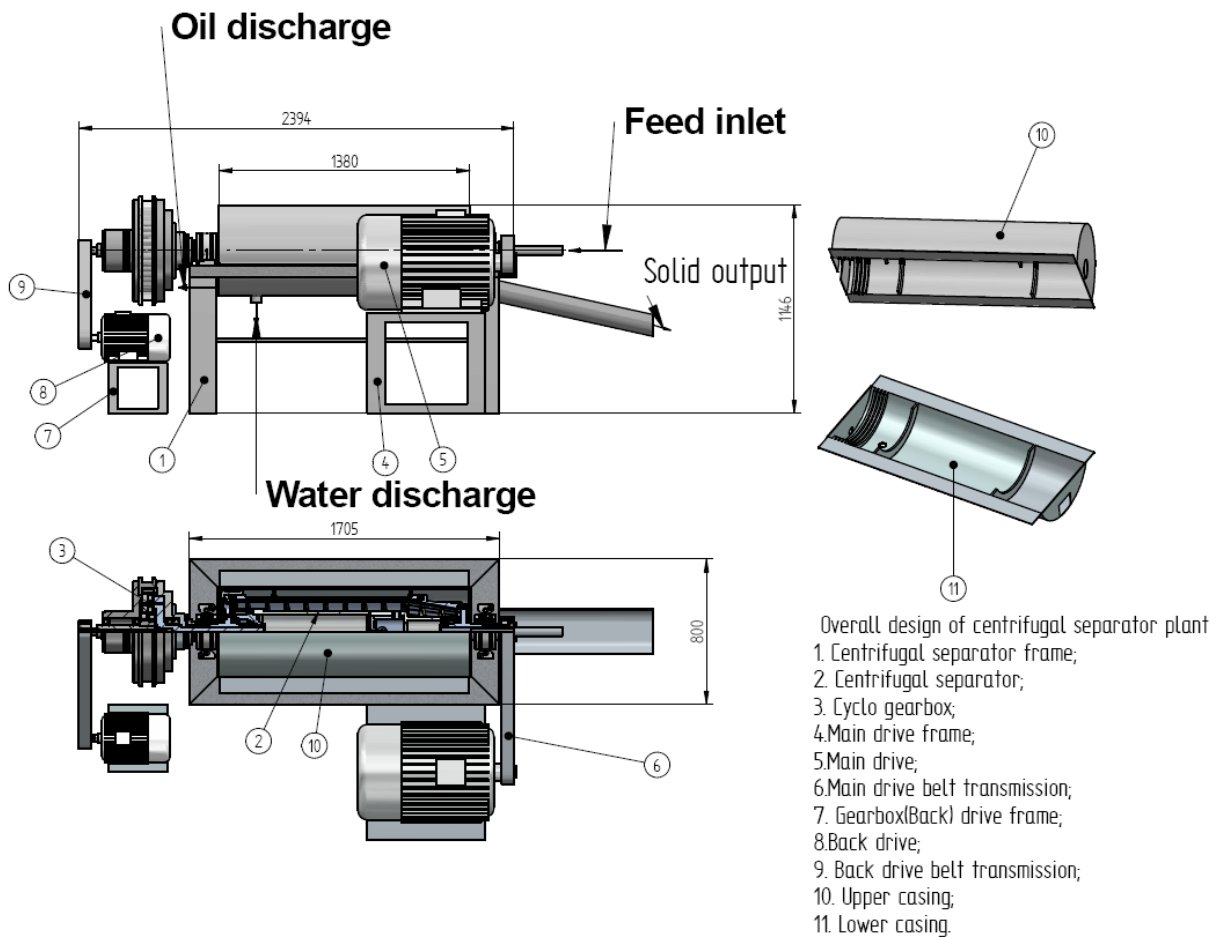

Reductor cicloidal

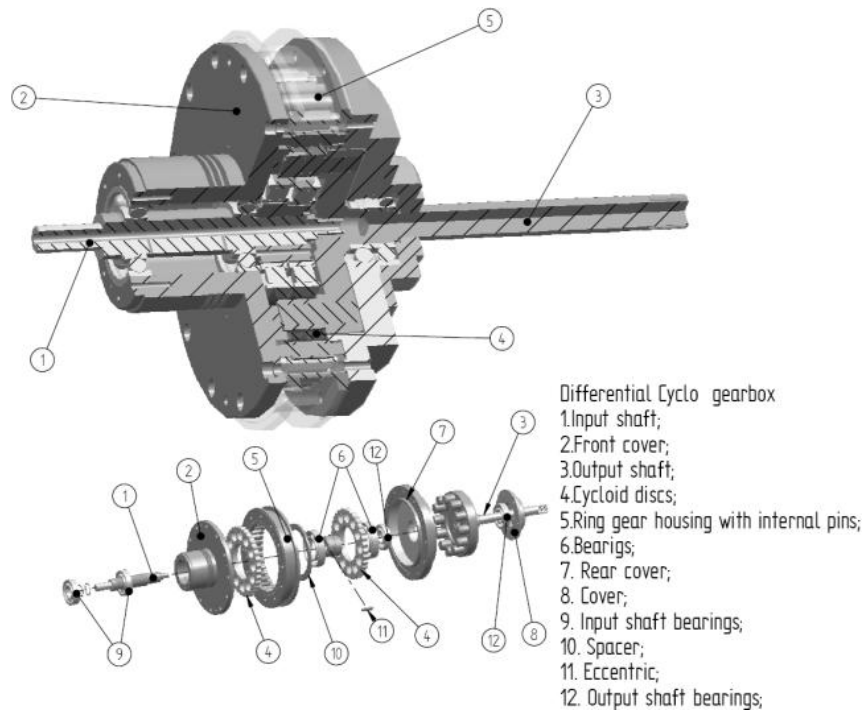

**Etapa 5 Detalii de executie a noii solutii de epurare a apelor infestate cu produse petroliere**

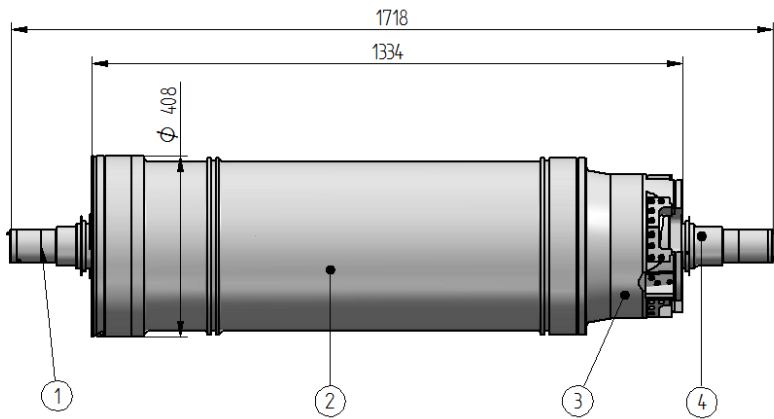

**Separator centrifugal-dimensiuni de gabarit**

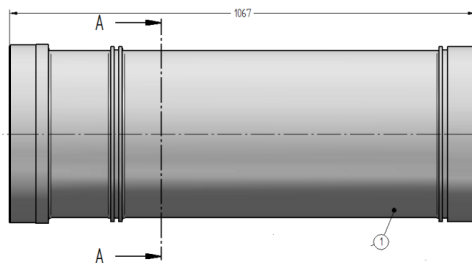

**Carcasa separator**

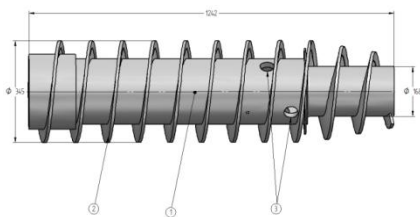

**Transportor**

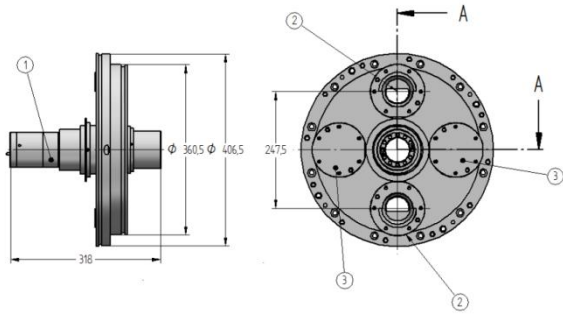

Ans. Arbore anterior

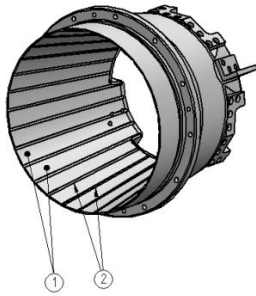

Confuzor

**Etapa 6 Definitivarea unei strategii comune de prevenire a riscurilor tehnologice de poluare a Dunarii cu petrol si produse petroliere . Diseminarea pe scara larga a rezultatelor proiectului**

Principiile strategiei

- Problema comuna – Rezolvare comuna
- Probleme abordate- Probleme total rezolvate
- Protectia mediului – Viata generatiei noastre si a generatiilor viitoare, ce nu poate fi pretuita
- Solutiile cele mai bune - Solutiile sustenabile si care promoveaza o dezvoltare durabile

« Cheia strategiei »

Strategia propusa in cadrul proiectului presupune procesarea, la fata locului a apei contaminate cu produse petroliere si reintegrarea in circuitul natural al apei si componentelor solide, petrolul obtinut fiind preluat in tancuri speciale, rezolvarea problemei fiind totala si imediata. Acest lucru este posibil utilizand **un echipament special de procesare prin centrifugare a apei poluate cu petrol, intr-o singura treapta si separarea in produse ecologice, apa solide si petrol**

Ce propune noua strategie

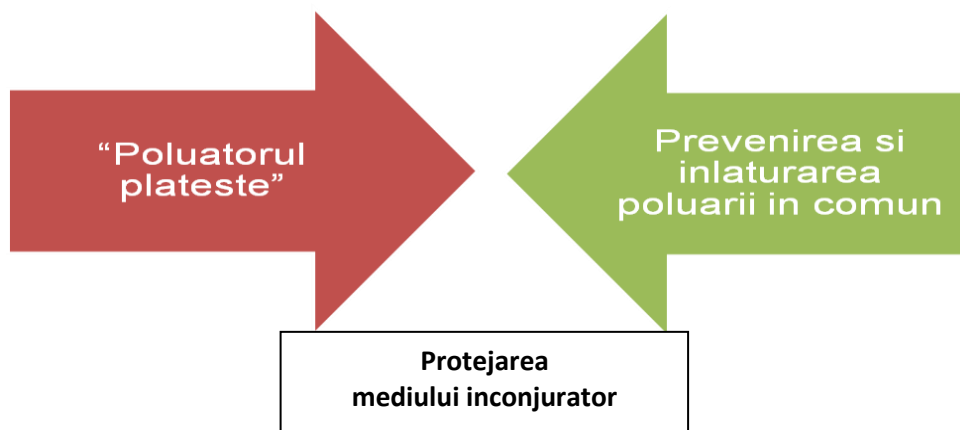

## **Avantajele strategiei**

- Posibilitatea de interventie imediata in cazul accidentelor, prevenirea- inlaturarea poluarii intr-o situatie fara solutie la aceasta data
- Scurtarea timpului si a costurilor necesare procesarii – epurarii apelor poluate cu petrol provenit de la curatarea tancurilor si rezervoarelor navelor
- Posibilitatea de a accesa usor zonele, locurile cu apa poluata
- Obtinerea printr-o singura operatie a trei produse, petrol, apa solide, cu proprietati ce se incadreaza in normele specific de calitate, ce pot fi redade imediat mediului inconjurator (apa si solide) sau proceselor industrial (petrolul)
- Eliminarea procesului de poluare colaterala a solului si panzei de apa freatica prin spatiile de depozitare existente la aceasta data

Tehnologia specifica de separare centrifugala a amestecului trifazic

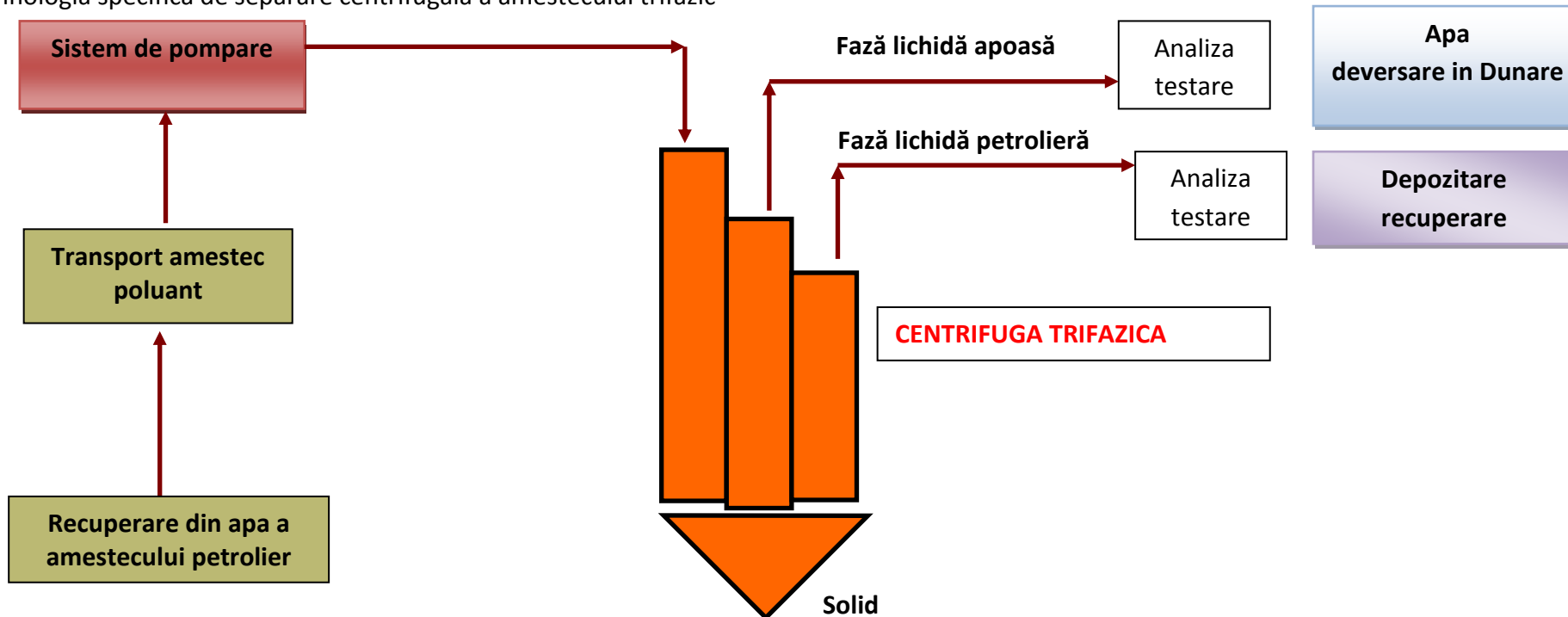

Schema de principiu a fazelor tehnologice de ecologizare a apelor contaminate cu produse petroliere

## Diseminarea pe scara larga a rezultatelor proiectului

- **Tematical workshop 04.02. - 05.02.2012 - INCDT COMOTI Bucuresti**



- **Workshop 29-02. - 01-03 2012 - INCDT COMOTI Bucuresti**



- **Conferinta 02.03-03.03.2012 - INCDT COMOTI Bucuresti**







Participare la manifestatiilor organizate in cinstea zilei Nationale a Bulgariei din 03.03.2012 la expoziția "Danube - an European River" (Museum of Bucharest)



- **Caravana promotional 05 ÷06.03 2012 Calarasi – Giurgiu – Ruse – Silistra**

